

**S2S65A30**  
**Evaluation Board**  
**Technical Manual**

**S5U2S65A30H0100**

## NOTICE

---

No part of this material may be reproduced or duplicated in any form or by any means without the written permission of Seiko Epson. Seiko Epson reserves the right to make changes to this material without notice. Seiko Epson does not assume any liability of any kind arising out of any inaccuracies contained in this material or due to its application or use in any product or circuit and, further, there is no representation that this material is applicable to products requiring high level reliability, such as, medical products. Moreover, no license to any intellectual property rights is granted by implication or otherwise, and there is no representation or warranty that anything made in accordance with this material will be free from any patent or copyright infringement of a third party. This material or portions thereof may contain technology or the subject relating to strategic products under the control of the Foreign Exchange and Foreign Trade Law of Japan and may require an export license from the Ministry of Economy, Trade and Industry or other approval from another government agency.

All brands or product names mentioned herein are trademarks and/or registered trademarks of their respective companies.

## Configuration of product number

### ● Device

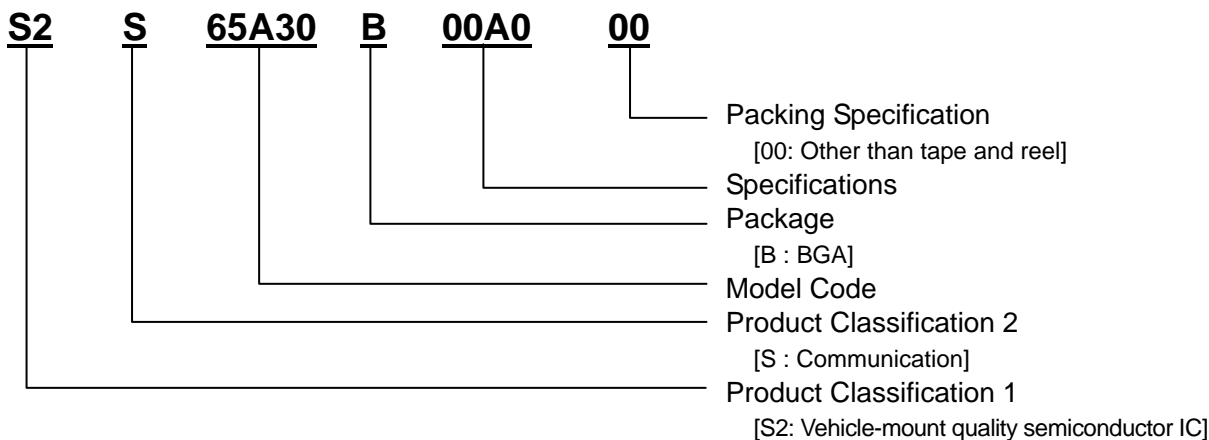

### ● Development tool

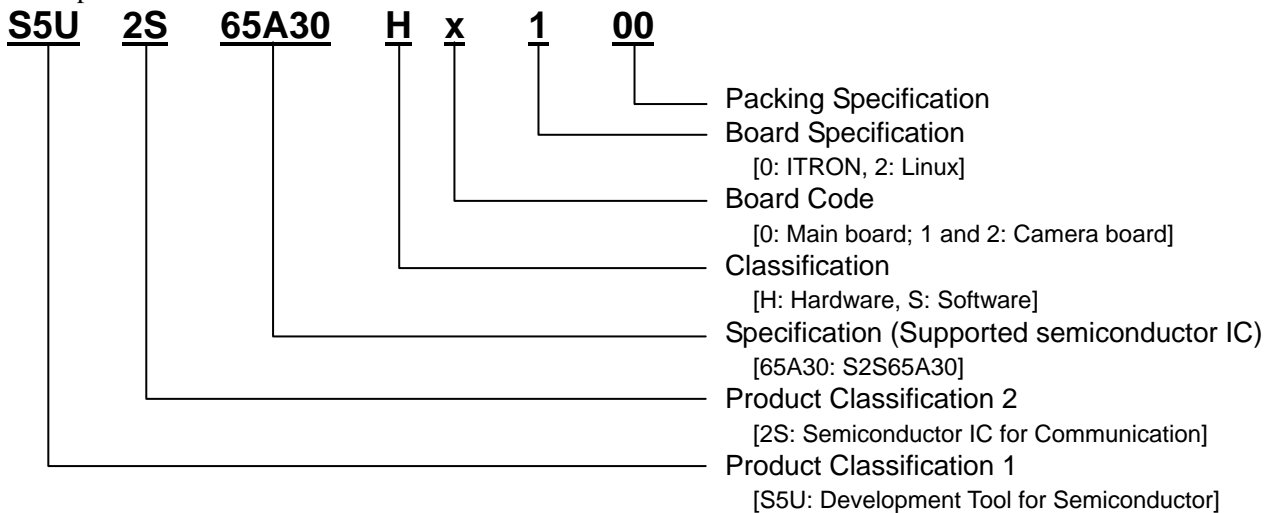

# Table of Contents

<b>1. Main Board</b> .....	<b>1</b>
<b>1.1 DESCRIPTIONS</b> .....	<b>1</b>
<b>1.2 CONFIGURATION</b> .....	<b>1</b>
1.2.1 Components.....	1
1.2.2 Memory IC Mapping.....	1
1.2.3 Block Diagram.....	2
<b>1.3 EXTERNAL PINS</b> .....	<b>3</b>
1.3.1 Interface connector Layout.....	3
1.3.1.1 Camera Interface Connectors.....	4
1.3.1.2 SRAM Interface (CN10).....	6
1.3.1.3 JTAG-ICE Interface (CN7).....	6
1.3.1.4 Serial Port (RS232C) Pins (CN5 and CN9).....	7
1.3.1.5 Power Supply Connector (CN11).....	7
1.3.1.6 CF-CARD Interface (CN12).....	7
1.3.1.7 SD-CARD Interface (CN6).....	8
1.3.1.8 USB Interface (CN4).....	8
1.3.1.9 ADC Interface (CN8).....	8
1.3.1.10 GPIOInterface (CN3).....	8
<b>1.4 FUNCTIONAL DESCRIPTION</b> .....	<b>9</b>
1.4.1 Mode Select DIP-SW (SW11) .....	9
1.4.2 GPIOC4, 5, and 7 DIP-SW (SW6).....	9
1.4.3 Hardware Reset Switch (SW3).....	9
1.4.4 SDRAM Chip Select Switch (SW8) .....	9
1.4.5 TimerBin/GPIOB7 Switch (SW4).....	10
1.4.6 TimerA2Out/GPIOB6 Switch (SW12).....	10
1.4.7 TimerA1Out/GPIOB5 Switch (SW5).....	10
1.4.8 Push Switch (SW2).....	10
1.4.9 CTS2/I <sup>2</sup> C_SDA/GPIOA7 and RTS2/I <sup>2</sup> C_SCL/GPIOA6 Switch (SW9).....	11
1.4.10 CF/SD Select DIP-SW (SW13) .....	11
1.4.11 Clock Select DIP-SW (SW7) .....	11
1.4.12 RTC (Real-Time Clock) Select DIP-SW (SW1) .....	11
1.4.13 Power SW (SW14).....	12
<b>1.5 SPECIFICATIONS</b> .....	<b>13</b>
1.5.1 Power Supply.....	13
<b>1.6 NOTE ON USING THIS BOARD</b> .....	<b>13</b>
<b>1.7 PARTS LIST</b> .....	<b>14</b>
<b>2. Camera Board</b> .....	<b>15</b>
<b>2.1 OVERVIEW</b> .....	<b>15</b>
<b>2.2 COMPONENTS</b> .....	<b>15</b>
2.2.1 Main Parts.....	15
2.2.2 Block Diagram.....	15
<b>2.3 EXTERNAL PINS</b> .....	<b>16</b>
2.3.1 Interface Connectors.....	16
2.3.1.1 Main Board Interfaces Main Board Interfaces.....	16
2.3.1.2 Audio Interface Connectors (CN1 to CN4).....	18
2.3.1.3 An Analog Camera Connector (CN0).....	18
<b>2.4 FUNCTIONAL DESCRIPTION</b> .....	<b>19</b>
2.4.1 GPIOB DIP Switches (SW1) .....	19
2.4.2 Video decoder setting Switch (SW3).....	19

2.4.3 AUDIO CODEC Switch (SW2) .....	20
2.4.4 AUDIO CODEC Clock Input (J1) .....	20
2.4.5 I2C monitor pin (J2).....	20
2.4.6 Power Supply monitor (J3).....	21
<b>2.5 Camera board PARTS LISTS .....</b>	<b>21</b>
<b>3. Revision History .....</b>	<b>22</b>

## 1. Main Board

### 1.1 DESCRIPTIONS

This product, the S2S65A30 Evaluation Board, is an optimum evaluation board for building a drive recorder easily with Seiko Epson's Drive Recorder Chip: S2S65A30.

When connected with an analog camera board or a camera board (Model No.: S5U1S65K01H3100, separately available), this product can be used for checking sample code operations and developing firmware.

### 1.2 CONFIGURATION

#### 1.2.1 Components

Drive recorder IC	: S2S65A30
Flash ROM	: 16 Mbytes (S29GL128P90FFIR20S manufactured by Spansion)
SDRAM	: 64 Mbytes (MT48LC32M16AP-75 manufactured by MICRON) × 2 Two 16-bit SDRAMs are used to compose a 32-bit bus.
JTAG DEBUG interface	: Provides a 20-pin connector for ICE/DEBBUG.
Camera board interface	: Provides two channels of 16/40-pin connectors for connecting to a camera board.
I <sup>2</sup> C	: An interface for camera control is assigned to the above connector.
I <sup>2</sup> S	: An interface for monaural CODEC_IC connection is assigned to the camera board. * The camera board I/F supports channel 1 only.
GPIO	: Assigned to the above camera board I/F connector for GPIO evaluation.
Serial interface	: Provides two channels of D-sub connectors for RS232C.
USB interface	: Provides a mini B connector.
CF card interface	: Provides a CF card connector.
SD card interface	: Provides an SD card connector.
Supply voltage	: 5V±10%

#### 1.2.2 Memory IC Mapping

0x0000_0000 to 0x00FF_FFFF	Flash ROM 16MByte
0x4000_0000 to 0x47FF_FFFF	SDRAM 128 Mbytes (when SW8 is "1,2pin short")
0x5000_0000 to 0x57FF_FFFF	SDRAM 128 Mbytes (when SW8 is "2,3pin short")

\* The sample firmware uses a memory mapping where SW8 is "1,2pin short".

# 1. Main Board

## 1.2.3 Block Diagram

Fig. 1.2-1 shows a block diagram of this evaluation board.

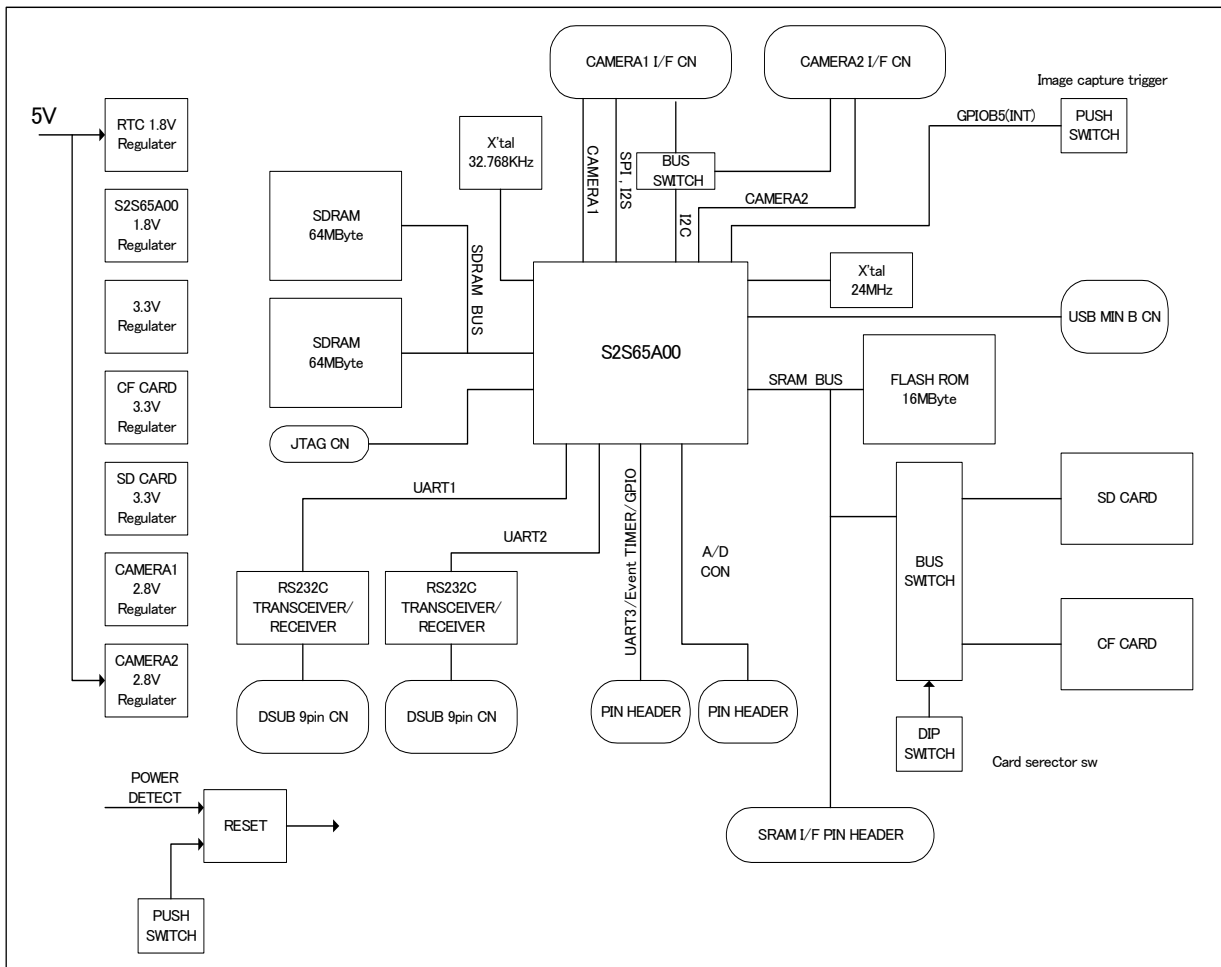

Fig. 1.2.1 Block Diagram

1.3 EXTERNAL PINS

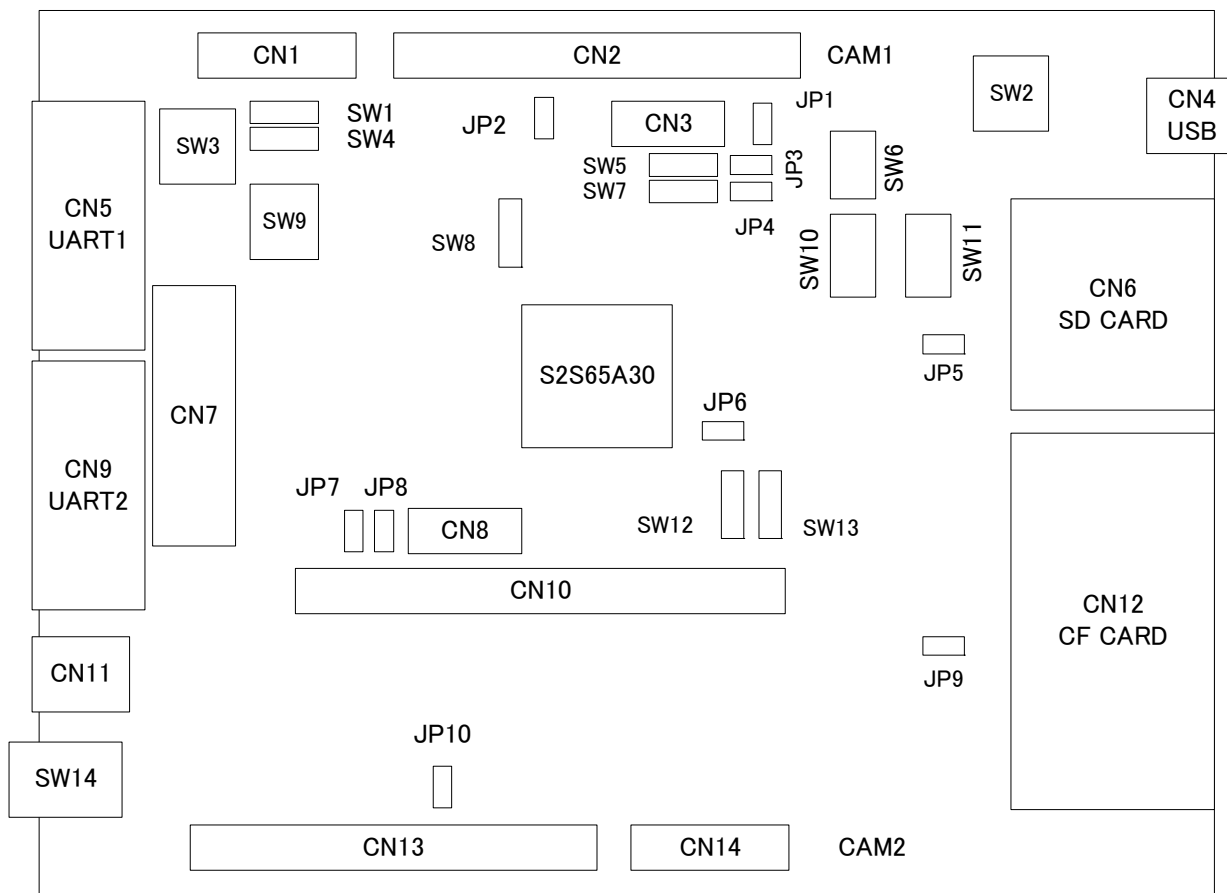

Fig.1.3.1 Interface Connector Layout

1.3.1 Interface connector Layout

Fig. Fig.1.3.1 shows the locations of the external interfaces on the board. The correspondences between pin numbers and signal names are shown in Sections 1.3.1.1 to 1.3.1.10.



# 1. Main Board

## 1.3.1.1 Camera Interface Connectors

- 1) RESET, 5 V power supply (CN1,CN14)

Table 1.3-1 Camera Interface Connector

Pin No.	Signal name	Pin No.	Signal name
1	VDD (5V)	2	VDD (5V)
3	NC	4	NC
5	NC	6	NC
7	NC	8	NC
9	NC	10	NC
11	NC	12	NC
13	RESET#	14	GND
15	GND	16	GND

\* RESET# is used on the camera board.

- 2) Camera interface connector ch1 (CN2)

Table 1.3-2 Camera interface connector

Pin No.	Signal name	Pin No.	Signal name
1	GND	2	GND
3	CAMDATA0/ IPCDATA0	4	CAMDATA1/ IPCDATA1
5	CAMDATA2/ IPCDATA2	6	CAMDATA3/ IPCDATA3
7	CAMDATA4/ IPCDATA4	8	CAMDATA5/ IPCDATA5
9	CAMDATA6/ IPCDATA6	10	CAMDATA7/ IPCDATA7
11	CMCLKOUT/ IPC1FIELD	12	CMCLKIN/ IPC1CLKIN
13	CMVREF/ IPC1VREF	14	CMHREF/ IPC1HREF
15	CAMVDD	16	CAMVDD
17	I2C_SDA	18	I2C_SCL
19	3.3V	20	3.3V
21	NC	22	NC
23	GPIOC4 (TXD3/SPI_SS)	24	GPIOC5 (RXD3/SPI_SCLK)
25	NC	26	GPIOC7 (SPI_MOSI)
27	NC	28	NC
29	GPIOB0 (I2S_WS)	30	GPIOB1 (I2S_SCK)
31	GPIOB2 (I2S_SD)	32	GPIOB3 (I2SI_SD)
33	GPIOB4 (TimerA0out)	34	NC
35	NC	36	NC
37	NC	38	NC
39	GND	40	GND

\* In the sample firmware, OSC1 on a analog camera board is used for the clock for the Audio Codec IC installed on the camera board.

## 3) Camera interface connector ch2 (CN13)

Table 1.3-3 Camera interface connector

Pin No.	Signal name	Pin No.	Signal name
1	GND	2	GND
3	CAMDATA0/ IPC2DAT0	4	CAMDATA1/ IPC2DAT1
5	CAMDATA2/ IPC2DAT2	6	CAMDATA3/ IPC2DAT3
7	CAMDATA4/ IPC2DAT4	8	CAMDATA5/ IPC2DAT5
9	CAMDATA6/ IPC2DAT6	10	CAMDATA7/ IPC2DAT7
11	CMCLKOUT/ IPC2FIELD	12	CMCLKIN/ IPC2CLKIN
13	CMVREF/ IPC2VREF	14	CMHREF/ IPC2HREF
15	CAMVDD	16	CAMVDD
17	I2C_SDA	18	I2C_SCL
19	3.3V	20	3.3V
21	NC	22	NC
23	NC	24	NC
25	NC	26	NC
27	NC	28	NC
29	NC	30	NC
31	NC	32	NC
33	NC	34	NC
35	NC	36	NC
37	NC	38	NC
39	GND	40	GND

\* It is not possible to control the Audio Codec IC on the camera board from the camera 2ch connector.

## 1. Main Board

### 1.3.1.2 SRAM Interface (CN10)

Table 1.3-4 SRAM Interface connector

Pin No.	Signal name	Pin No.	Signal name
1	MD0	2	MD1
3	MD2	4	MD3
5	MD4	6	MD5
7	MD6	8	MD7
9	GND	10	GND
11	MD8	12	MD9
13	MD10	14	MD11
15	MD12	16	MD13
17	MD14	18	MD15
19	GND	20	MCS1#
21	MA3	22	MOE#
23	TimerA0Out/GPIOB4	24	GND
25	MWE#	26	MWE#
27	MOE#	28	NC
29	3.3V	30	REST#
31	GND	32	NC
33	MA2	34	MA1
35	MA0	36	GND
37	GND	38	3.3V
39	MA4	40	MA5
41	MA6	42	MA7
43	MA8	44	MA9
45	DREQ#	46	TimerB3IO/GPIOC3
47	MCS2#	48	DACK#
49	MBEH#	50	MBEL#

### 1.3.1.3 JTAG-ICE Interface (CN7)

Table 1.3-5 JTAG-ICE Interface

Pin No.	Signal name	Pin No.	Signal name
1	3.3V	2	3.3V
3	nTRST	4	GND
5	TDI	6	GND
7	TMS	8	GND
9	TCK	10	GND
11	GND	12	GND
13	TDO	14	GND
15	nSRST	16	GND
17	NC	18	GND
19	NC	20	GND

## 1.3.1.4 Serial Port (RS232C) Pins (CN5 and CN9)

Table 1.3-6 Serial Port (RS232C) Pins

Pin No.	Signal name	Pin No.	Signal name
1	NC	2	RXD
3	TXD	4	NC
5	GND	6	NC
7	RTS	8	CTS
9	NC	10	NC

\* Conforms to the layouts on PC motherboards manufactured by ASUS and GIGABYTE.

## 1.3.1.5 Power Supply Connector (CN11)

Use the AC adapter that comes with the product.

## 1.3.1.6 CF-CARD Interface (CN12)

Table 1.3-7 CF-CARD Interface

Pin No.	Signal name	Pin No.	Signal name
1	GND	2	D3 (CF_D3)
3	D4 (CF_D4)	4	D5 (CF_D5)
5	D6 (CF_D6)	6	D7 (CF_D7)
7	CE1# (CFCE1#)	8	A10 (MA10)
9	OE# (CFOE#)	10	A9 (MA9)
11	A8 (MA8)	12	A7 (MA7)
13	VCC1 (3.3V)	14	A6 (MA6)
15	A5 (MA5)	16	A4 (MA4)
17	A3 (MA3)	18	A2 (MA2)
19	A1 (MA1)	20	A0 (MA0)
21	D0 (CF_D0)	22	D1 (CF_D1)
23	D2 (CF_D2)	24	WP (NC)
25	CD2#	26	CD1#
27	D11 (CF_D11)	28	D12 (CF_D12)
29	D13 (CF_D13)	30	D14 (CF_D14)
31	D15 (CF_D15)	32	CE2# (CFCE2#)
33	VS1# (NC)	34	IORD# (CFIORD#)
35	IOWR# (CFIOWR#)	36	WE# (MWE0#)
37	RDY/BSY (CFIREQ)	38	VCC1 (3.3V)
39	CSEL# (CSEL#)	40	VS2# (NC)
41	RESET (CFRST_CN)	42	WAIT# (CFWAIT#)
43	INPACK# (NC)	44	REG# (REG#)
45	BVD2 (BVD2/DASP)	46	BVD1 (CFSTSCHG#)
47	D8 (CF_D8)	48	D9 (CF_D9)
49	D10 (CD_D10)	50	GND

\* Pins VS1#, VS2#, WP, INPACK#, and BVD2 are not supported on the S2S65A30, so they are not also used on this evaluation board.  
Pins CD1# and CD2# are not also supported on the S2S65A30.  
However, a logic-based circuit that detects insertion and removal of a card is installed. The sample firmware does not support the detection of card insertion/removal.

## 1. Main Board

---

### 1.3.1.7 SD-CARD Interface (CN6)

Table 1.3-8 SD-CARD Interface

Pin No.	Signal name	Pin No.	Signal name
1	SDMDAT3	2	SDCMD
3	GND	4	VDD(SD3.3V)
5	SDMCLK	6	GND
7	SDMDAT0	8	SDMDAT1
9	SDMDAT2		

\* The sample firmware does not support the detection of card insertion/removal.

### 1.3.1.8 USB Interface (CN4)

Table 1.3-9 USB Interface

Pin No.	Signal name	Pin No.	Signal name
1	VBUS	2	D-
3	D+	4	NC
5	GND		

### 1.3.1.9 ADC Interface (CN8)

Table 1.3-10 ADCInterface

Pin No.	Signal name	Pin No.	Signal name
1	AVDD	2	ADIN0
3	ADIN2	4	ADIN1
5	ADIN4	6	ADIN3
7	ADIN6	8	ADIN5
9	ADIN7	10	AVSS

### 1.3.1.10 GPIOInterface (CN3)

Table 1.3-11 GPIOC Interface

Pin No.	Signal name	Pin No.	Signal name
1	GPIOC0 (TimerB0IO)	2	GPIOC1 (TimerB1IO)
3	GPIOC2 (TimerB2IO)	4	GPIOC3 (TimerB3IO)
5	GPIOC4 (SPI_SS/TXD3)	6	GPIOC5 (SPI_SCLK/RXD3)
7	GPIOC6 (SPI_MISO/RTS3)	8	GPIOC7 (SPI_MOSI/CTS3)
9	GND	10	GND

## 1.4 FUNCTIONAL DESCRIPTION

Fig.1.3.1 shows the locations of the switches on the board surface.

### 1.4.1 Mode Select DIP-SW (SW11)

Table1.4-1 Mode Selection

No.	Abbreviation	Function		Sample firmware	Remarks
		0 (OFF)	1 (ON)		
1	MD0 (MODESEL0)	Reserved		-	Set this OFF.
2	MD1 (MODESEL1)	Reset release waiting time MD[2:1]=00 : about 3sec		-	
3	MD2 (MODESEL2)	MD[2:1]=01 : about 100msec MD[2:1]=00 : about 20msec MD[2:1]=00 : about 2msec		-	
4	MD3 (MODESEL3)	For user setting Stored at 0xFFFF_D004 in the Chip Configuration Register at a rise of RESET#.		-	
5	MD4 (MODESEL4)			-	
6	MD5 (MODESEL5)			-	

### 1.4.2 GPIOC4, 5, and 7 DIP-SW (SW6)

This switch selects where GPIOBC4, 5, and 7 are connected to. The correspondence between pins is shown in the table below. When using the Audio Codec IC on camera board ch1, set pins 1, 3, and 5 of SW9 to ON. The sample firmware uses an Audio Codec IC.

Table1.4-2 GPIOC Setting SW

No.	Abbreviation	Function		Sample firmware	Remarks
		0 (OFF)	1 (ON)		
1	GPIOC4 (SPI_SS/TXD3)	Open	CN2 23pin に接続	ON	CAMERA1
2		Open	CN3 5pin に接続	OFF	
3	GPIOC5 (SPI_SCLK/RXD3)	Open	CN2 24pin に接続	ON	CAMERA1
4		Open	CN3 6pin に接続	OFF	
5	GPIOC7 (SPI_MOSI/CTS3)	Open	CN2 26pin に接続	ON	CAMERA1
6		Open	CN3 8pin に接続	OFF	

### 1.4.3 Hardware Reset Switch (SW3)

This switch resets the hardware. Use this switch if necessary.

### 1.4.4 SDRAM Chip Select Switch (SW8)

This switch selects the chip select signals of the SDRAM. The correspondence between pins is shown in the table below. In the sample firmware, this switch is set to 1,2 pin short to use SDCS0#.

Table1.4-3 Chip Select setting SW

Pin setting	SDCSx#(SDRAM の CS#)	Remarks
1,2pin short	SDCS0# (S2S65A30 output)	0x4000_0000~
2,3pin short	SDCS1# (S2S65A30output)	0x5000_0000~

\*Jumper 3pin is S2S65A30 side.

## 1. Main Board

---

### 1.4.5 TimerBin/GPIOB7 Switch (SW4)

This switch selects where the TimerBin/GPIOB7 signal is connected to. The correspondence between pins is shown in the table below.

In the sample firmware, this switch is set to “2,3pin short” to use GPIOB7 for switching I<sup>2</sup>C BUS of CAMERA1 and CAMERA2.

Table 1.4-4 TimerBin/GPIOB7 SW

Pin setting	TimerBin/GPIOB7	Remarks
1,2pin short	Connected to TH1	TH (Through Hole)
2,3pin short	Used for OE# control of U19 and U20.	GPIOB7(Low): I <sup>2</sup> C of CAMERA1 is enabled. GPIOB7(High): I <sup>2</sup> C of CAMERA2 is enabled.

\*Jumper 1pin is TH1 side.

### 1.4.6 TimerA2Out/GPIOB6 Switch (SW12)

This switch selects where the TimerA2Out/GPIOB6 signal is connected to. The correspondence between pins is shown in the table below. In the sample firmware, this switch is not used.

Table1.4-5 TimerBin/GPIOB7 SW

Pin setting	TimerA2Out/GPIOB6	Remarks
1,2pin short	Connected to TH5	TH (Through Hole)
2,3pin short	Used for CF card detection.	GPIOB6(Low): CF card inserted GPIOB6(High): CF card not inserted

\*Jumper 1pin is TH5 side.

### 1.4.7 TimerA1Out/GPIOB5 Switch (SW5)

This switch selects where the TimerA1Out/GPIOB5 signal is connected to. The correspondence between pins is shown in the table below.

In the sample firmware, this switch is set to “1,2pin short” to connect to Push SW (SW2), in order to use the GPIOB5 function as an image capture trigger.

Table1.4-6 TimerA1Out/GPIOB5 SW

Pin setting	TimerA1Out/GPIOB5	Remarks
1,2pin short	Connected to TH2	TH(Through Hole)
2,3pin short	Used as an image capture trigger.	

\*Jumper 1pin is TH2 side.

### 1.4.8 Push Switch (SW2)

This switch is connected to the TimerA1Out/GPIOB5 signal. In the sample firmware, this switch is used as an image capture trigger. When pressed, it connects to the GND.

1.4.9 CTS2/I<sup>2</sup>C\_SDA/GPIOA7 and RTS2/I<sup>2</sup>C\_SCL/GPIOA6 Switch (SW9)

This switch is used to select whether to use the CTS2/I<sup>2</sup>C\_SDA/GPIOA7 and CTS2/I<sup>2</sup>C\_SCL/GPIOA6CF signals as the I<sup>2</sup>C function for controlling the camera or as control pins (RTS and CTS) of UART2. In the sample firmware, this switch is set to “1” to use them as the I<sup>2</sup>C function.

Table 1.4-7 Setting Switch for I<sup>2</sup>C and UART2 Control SW

Location	CTS2/I <sup>2</sup> C_SDA/GPIOA7	RTS2/I <sup>2</sup> C_SCL/GPIOA6	Remarks
1	I2C_SDA	I2C_SCL	CAMERA control
A	CTS2	RTS2	UART2

## 1.4.10 CF/SD Select DIP-SW (SW13)

Either a crystal oscillator element or a crystal oscillator device can be used as a 32,768-KHz clock input for the S2S65A30. This evaluation board has a crystal oscillator element only. Set this switch to the OFF position.

Table1.4-8 Clock Select Switch

Pin setting	CF/SD	Remarks
1,2pin short	CF card	
2,3pin short	SD card	

\* For sample firmware supporting SD cards, contact our sales representative.

## 1.4.11 Clock Select DIP-SW (SW7)

Either a crystal oscillator element or a crystal oscillator device can be used as a 32,768-KHz clock input for the S2S65A30. This evaluation board has a crystal oscillator element only. Set this switch to the OFF position.

Table1.4-9 Clock Select Switch

Pin setting	Function	Remarks
1,2pin short	Device	No mount
2,3pin short	Element	

\* You can install and use a crystal oscillator device.

\*Jumper 1pin is TH2 side.

## 1.4.12 RTC (Real-Time Clock) Select DIP-SW (SW1)

On the S2S65A30, the main power can be turned off to supply power to the RTC only so that the RTC (real-time clock function) operates with low power consumption.

Table1.4-10 BUP# pin Select Switch

Pin setting	BUP# pin	Remarks
1,2pin short	High	
2,3pin short	Low	

\*Jumper 1pin is TH1 side.



## 1. Main Board

---

### 1.4.13 Power SW (SW14)

This switch is used to turn ON or OFF the power to the evaluation board. When this switch is ON, power is supplied to all components. When this switch is OFF, power is supplied only to the RTC on the S2S65A30. Note that not all the power is turned OFF.

The following describes how to use the Power SW (SW14) and RTC SW (SW1) on the evaluation board.

1) How to turn the main power OFF to operate the RTC (clock) only

Step 1 – Short 1pin and 2pin(or open) of SW1:

This step turns the BUP# pin on the S2S65A30 Low and inhibits access to the register and memory in the RTC from the internal CPU of the S2S65A30. This protects the RTC register and memory from instability that can occur when the main power is turned OFF.

Step 2 - Turn SW14 OFF: This step turns OFF the power to all components except the S2S65A30 RTC on the board. This establishes the mode where only the RTC operates.

2) How to turn the main power on to operate the entire system from the mode where only the RTC operates

Step 1 - Turn SW14 ON: This step turns ON the power to all components on the board. This establishes the mode where the entire system operates.

Step 2 - Short 2pin and 3pin :This step turns the BUP# pin on the S2S65A30 High and permits access to the register and memory in the RTC from the internal CPU of the S2S65A30. It becomes possible to refer to and acquire the time.

## 1.5 SPECIFICATIONS

### 1.5.1 Power Supply

This board generates seven types of power from the  $5\text{ V} \pm 10\%$  power input from CN11.

Table1.5-1 Use of Power Supply (Main Board)

	Location	Parts	Use	Remarks
3.3V generator	U28	SPX3819M5-3.3 JP7	Power to the I/O and chips on the S2S65A30	
CF3.3V generator	U32	SPX3819M5-3.3 JP9	Power to the CF card	Power is supplied when a CF card is inserted.
SD3.3V generator	U15	SPX3819M5-3.3 JP5	Power to the SD card	Power is supplied when an SD card is inserted.
CAM1 2.8V generator	U2	SPX3819M5-LR JP2	Power to CAMERA1	
CAM2 2.8V generator	U39	SPX3819M5-LR JP10	Power to CAMERA2	
1.8V generator	U21	SPX3819M5-1.8 JP6	Core and analog PLL power to the S2S65A10	
RTC1.8V generator	U25	SPX3819M5-1.8 JP8	RTC Power to the S2S65A30	

\* When two cameras operating on the same voltage are used, it is not necessary to use separate power supplies. However, for evaluation purposes, separate power supplies are used on this board.

## 1.6 NOTE ON USING THIS BOARD

This board is not ready for live-wire insertion and removal operations on the CF and SD cards. Insert or remove the CF card only when the power is OFF.

Turning the Power SW (SW14) OFF does not turn OFF all components. The RTC is always supplied with 1.8 V power. When not using the board, remove the AC/DC adapter from the outlet.

## 1.7 PARTS LIST

Table 1.7-1 lists the major parts installed on the board. (Chip resistors and capacitors are not listed.)

Circuit diagrams and detailed parts list are (will be) available at our website. Download them as necessary or contact our sales representative.

table 1.7-2 Parts List

variety	Comment	Designator	Quantity	Provider
Crystal	MC-30A 32.768KHz	X1	1	EPSON
	FA-23A 24MHz	X2	1	EPSON
IC	S2S65A30	U20	1	EPSON
	SN74LVC1G32DBVR	U18,U23,U33,u34,U38	5	TI
	MC34063	U36	1	ST
	ST3232ECTR	U7,U31	2	ST
	MT48LC32M16A2P-75	U10,U22	2	micron
	SPX3819M5-1.8	U21,U25	2	SPX
	SN74LVC1G14DBVR	U1, U3, U4, U9, U13, U14, U19, U24, U37	9	TI
	SPX3819M5-3.3	U15,U28,U32	3	SPX
	SPX3819M5-LR	U2,U39	2	SPX
	S29GL128P90FFIR20	U29	1	Spansion
	PCF8574	U5,U11	2	TI
	74VCX16245TTR	U30,U35	2	ST
	74LX1G08	U16	1	ST
	SN74CBTLV3861	U6,U8,U17,U26	4	TI
	SN74CBTLV1G125DBVR	U27	1	TI
Connect	CF-50P	CN12	1	
	54819-0572	CN4	1	
	SD CARD	CN6	1	
	2213S-16G	CN1	1	
	2213S-16G	CN14	1	
	2213S-40G	CN2,CN13	2	
	DB9M	CN9,CN5	2	
	DS-210-B	CN11	1	
	21136NA	SW14	1	
	EHS-108	SW10,SW11	2	
	SCS-1G2-023	SW9	1	
	2211S-3G	SW1, SW4,SW5, SW7, SW8,SW12,SW13	7	
	2211S-2G	JP1,JP2,JP3,JP4,JP5~JP10	10	
	2213S-50G	CN10		
	2213S-10G	CN3,CN8	1	
	2316S-20G	CN7		
	TD0341XD	SW2,SW3	2	
	EHS-106	SW6	1	
TEST-1	TH1,TH2,TH3,TH4,TH5,TH6,TP1~TP5	11		

## 2. Camera Board

### 2.1 OVERVIEW

This product is an evaluation board used when it connects with the S2S65A30 evaluation board and the drive recorder are constructed.

### 2.2 COMPONENTS

#### 2.2.1 Main Parts

Vide Decoder	AK8853(ASAHIKASEI)
Audio Codec	Monaural CODEC (ASAHIKASEI AK4631)
Main Board I/F	Preparation of the connector of 40/16pin for S2S65A30 evaluation board joint
Audio I/F	Speaker, MIC, Line Input, Line Output

#### 2.2.2 Block Diagram

The following figure gives block diagram for camera board. An analog camera is not mounted. Please prepare it.

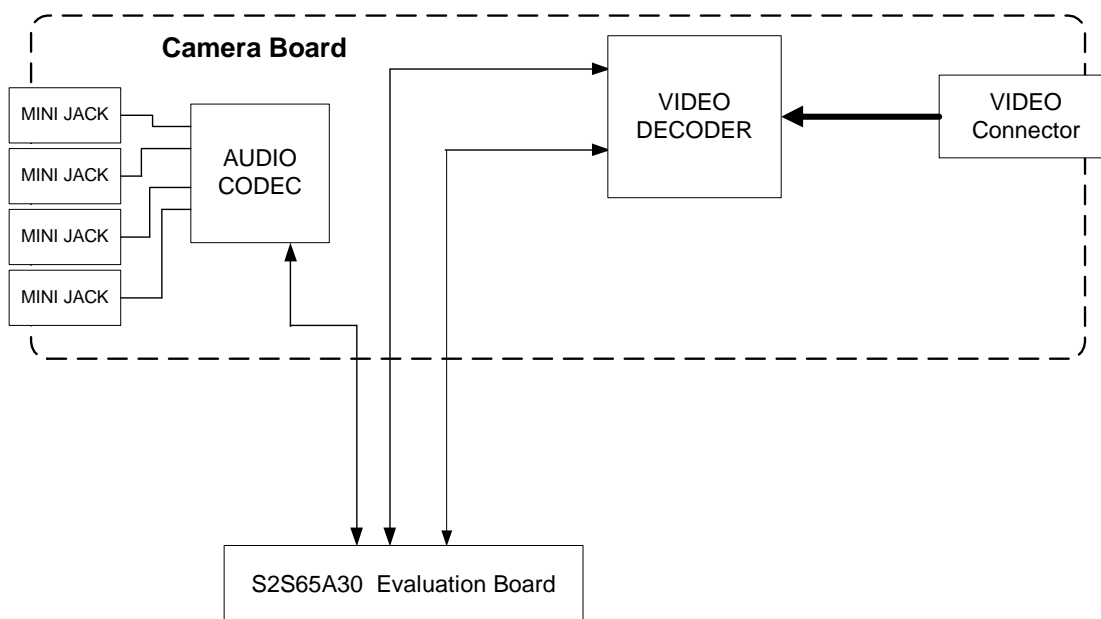

Fig. 2.2.1 Block Diagram

## 2. Camera Board

### 2.3 EXTERNAL PINS

#### 2.3.1 Interface Connectors

The following Figure shows the locations of the external interface connectors on the camera board. The Tables in the following four subsections list their pin assignments.

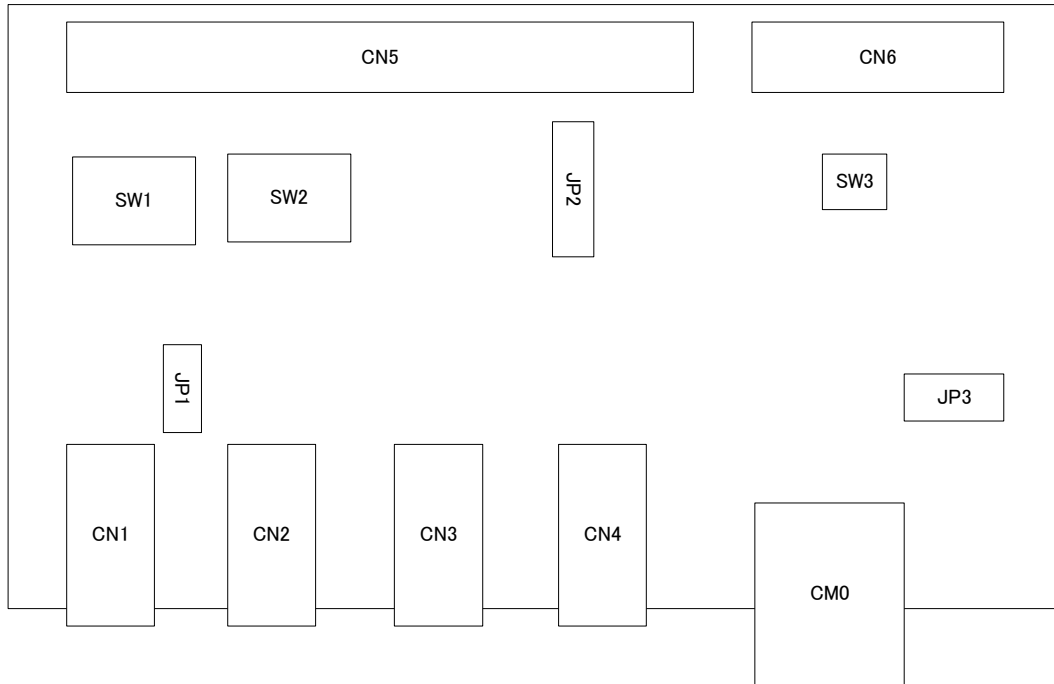

Fig. 2.3.1 Camera Board Interface Connector Layout

#### 2.3.1.1 Main Board Interfaces Main Board Interfaces

1)5V、Reset (CN6)

Table 2.3-1 5V, Reset

Pin Number	Function	Pin Number	Function
1	5V	2	5V
3	NC	4	NC
5	NC	6	NC
7	NC	8	NC
9	NC	10	NC
11	NC	12	NC
13	RESET#	14	GND
15	GND	16	GND

## 2) Camera interface and expansion connector (CN5)

## 2)-1 CAMERA1 of S2S65A30 Evaluation Board case of join

Table 2.3-2 pin location

Pin Number	Function	Pin Number	Function
1	GND	2	GND
3	IPC1DATA0	4	IPC1DATA1
5	IPC1DATA2	6	IPC1DATA3
7	IPC1DATA4	8	IPC1DATA5
9	IPC1DATA6	10	IPC1DATA7
11	NC	12	IPC1CLKIN
13	NC	14	NC
15	CAMVDD	16	CAMVDD
17	I2C_SDA	18	I2C_SCL
19	3.3V	20	3.3V
21	NC	22	NC
23	GPIOC4 (TXD3/SPI_SS)	24	GPIOC5 (RXD3/SPI_SCLK)
25	NC	26	SPI_MOSI
27	NC	28	NC
29	GPIOB0 (I2S0_WS)	30	GPIOB1 (I2S_SCK)
31	GPIOB2 (I2S_SDO)	32	GPIOB3 (I2S_SDI)
33	GPIOB4 (TimerA0out)	34	NC
35	NC	36	NC
37	NC	38	NC
39	GND	40	GND

## 2. Camera Board

---

②-2 CAMERA2 of S2S65A30 Evaluation Board case of join

Table 2.3-3 pin location

Pin Number	Function	Pin Number	Function
1	GND	2	GND
3	IPC2DATA0	4	IPC2DATA1
5	IPC2DATA2	6	IPC2DATA3
7	IPC2DATA4	8	IPC2DATA5
9	IPC2DATA6	10	IPC2DATA7
11	NC	12	IPC2CLKIN
13	NC	14	NC
15	CAMVDD	16	CAMVDD
17	I2C_SDA	18	I2C_SCL
19	3.3V	20	3.3V
21	NC	22	NC
23	NC	24	NC
25	NC	26	NC
27	NC	28	NC
29	NC	30	NC
31	NC	32	NC
33	NC	34	NC
35	NC	36	NC
37	NC	38	NC
39	GND	40	GND

### 2.3.1.2 Audio Interface Connectors (CN1 to CN4)

These are for a microphone, a speaker, and line I/O.

Table 2.3-4 Audio connectors

Connectorts	Function
CN1	Speaker Output
CN2	Line Output
CN3	BEEP
CN4	Microphone input

### 2.3.1.3 An Analog Camera Connector (CN0)

It is RCA connector for the camera input.

## 2.4 FUNCTIONAL DESCRIPTION

Fig. 2.3.1 Camera Board Interface Connector Layout show component locations on the board. The following nine subsections describe their functions.

- Please do not turn on SW1 and SW3 together.

### 2.4.1 GPIOB DIP Switches (SW1)

It is possible to control the LED by GPIOB from S2S65A30 evaluation board. It is the switch that joints the LED and GPIOB.

Table 2.4-1 Camera1 of S2S65A30 Evaluation Board case of joint

No.	Abbreviation	Function		Remarks
		0 (OFF)	1 (ON)	
1	LED7	NC		
2	LED6	NC		
3	LED5	NC		
4	LED4	NC	GPIOB4	
5	LED3	NC	GPIOB3	
6	LED2	NC	GPIOB2	
7	LED1	NC	GPIOB1	
8	LED0	NC	GPIOB0	

Table 2.4-2 Camera2 of S2S65A30 Evaluation Board case of joint

No.	Abbreviation	Function		Remarks
		0 (OFF)	1 (ON)	
1	LED7	NC		
2	LED6			
3	LED5			
4	LED4			
5	LED3			
6	LED2			
7	LED1			
8	LED0			

It is not possible the control of the LED on the camera board from S2S65A30 evaluation board.

### 2.4.2 Video decoder setting Switch (SW3)

Table 2.4-3 Video decoder

No.	Function		Remarks
	0 (OFF)	1 (ON)	
1	High	Low	Low:Power down
2	High	Low	H:Data output, L:Hi-z
3	High	Low	H:0x8A, L:0x88
4	NC	NC	-



## 2. Camera Board

### 2.4.3 AUDIO CODEC Switch (SW2)

It is the switch that joints Audio CODEC IC on the camera board and I2S, SPI of the S2S65A30 evaluation board.

Table 2.4-4 Camera1 of S2S65A30 Evaluation Board case of joint

No.	Function		Remarks
	0 (OFF)	1 (ON)	
1	NC	SPI_SS	
2		SPI_SCLK	
3		SPI_MOSI	
4		TIMERA0OUT	サンプルソフトは OSC1 を使用、SW は OFF
5		I2S_SDO	
6		I2S_SDI	
7		I2S_WS	
8		I2S_SCLK 接続	

Table 2.4-5 Camera2 of S2S65A30 Evaluation Board case of joint

No.	Function		Remarks
	0 (OFF)	1 (ON)	
1	NC		
2			
3			
4			
5			
6			
7			
8			

### 2.4.4 AUDIO CODEC Clock Input (J1)

The clock source of AUDIO CODEC AK4633 is set. In the sample software, OSC1 of the camera board is used for the clock. Please be short-circuited of J1, and open bit4 of SW2. The frequency of the mounted crystal oscillator is 12.288MHz.

### 2.4.5 I2C monitor pin (J2)

Table 2.4-6 I2C monitor pin

No.	Function
1	3.3V
2	GND
3	SCL
4	SDA

## 2.4.6 Power Supply monitor (J3)

Table 2.4-7 Power Supply monitor

No.	Function
1	CAMVDD(2.8V)
2	NC
3	5V

## 2.5 Camera board PARTS LISTS

The following Table lists the major parts on the camera board—that is, all parts except resistors and capacitors.

Table 2.5-1 Parts List

variety	Comment	Designator	Footprint	Quantity	Provider
IC	AK8853XQ	U5	QFN48	1	AKM
	AK4633VNCP	U1	QFN24	1	AKM
	SN74LVC1G14DBVR	U3,U4	SOT-23-5L	1	TI
	SPX3819M5-1.8	U2	SOT-23-5L	1	SPX
Connect	EHS-104	SW3	SO8-SW(1.27)	1	ECE
	EHS-108	SW1,SW2	SO16-SW(1.27)	2	ECE
	2211S-40G	CN5	2*20P(2*20)	1	
	2211S-16G	CN6	2*8P(2*8)	1	
	2211S-2G	JP1	SIP2(1*2)	1	
	ST309	CN1-CN4	PJST-309	4	
Crystal	FA-23A 24.576MHz	X1	FC-23A	1	
Oscirator	SG-310SCF	OSC1	SG-210	1	
RCA	TI-3C	CN0	RCA	1	

### 3. Revision History

---

### 3. Revision History

<b>Rev</b>	<b>Date</b>	<b>Description</b>	<b>Person</b>
1.0	2009/07/01	First Edition	T.Suzuki
1.1	2009/11/13	Fromat correction	T.Suzuki

### AMERICA

---

**EPSON ELECTRONICS AMERICA, INC.**

2580 Orchard Parkway,  
San Jose, CA 95131, USA  
Phone: +1-800-228-3964      FAX: +1-408-922-0238

### EUROPE

---

**EPSON EUROPE ELECTRONICS GmbH**

Riesstrasse 15, 80992 Munich,  
GERMANY  
Phone: +49-89-14005-0      FAX: +49-89-14005-110

### ASIA

---

**EPSON (CHINA) CO., LTD.**

7F, Jinbao Bldg., No.89 Jinbao St.,  
Dongcheng District,  
Beijing 100005, CHINA  
Phone: +86-10-6410-6655      FAX: +86-10-6410-7320

**SHANGHAI BRANCH**

7F, Block B, Hi-Tech Bldg., 900 Yishan Road,  
Shanghai 200233, CHINA  
Phone: +86-21-5423-5522      FAX: +86-21-5423-5512

**SHENZHEN BRANCH**

12F, Dawning Mansion, Keji South 12th Road,  
Hi-Tech Park, Shenzhen 518057, CHINA  
Phone: +86-755-2699-3828      FAX: +86-755-2699-3838

**EPSON HONG KONG LTD.**

20/F, Harbour Centre, 25 Harbour Road,  
Wanchai, Hong Kong  
Phone: +852-2585-4600      FAX: +852-2827-4346  
Telex: 65542 EPSCO HX

**EPSON TAIWAN TECHNOLOGY & TRADING LTD.**

14F, No. 7, Song Ren Road,  
Taipei 110, TAIWAN  
Phone: +886-2-8786-6688      FAX: +886-2-8786-6660

**EPSON SINGAPORE PTE., LTD.**

1 HarbourFront Place,  
#03-02 HarbourFront Tower One, Singapore 098633  
Phone: +65-6586-5500      FAX: +65-6271-3182

**SEIKO EPSON CORP.****KOREA OFFICE**

50F, KLI 63 Bldg., 60 Yoido-dong,  
Youngdeungpo-Ku, Seoul 150-763, KOREA  
Phone: +82-2-784-6027      FAX: +82-2-767-3677

---

**SEIKO EPSON CORP.****SEMICONDUCTOR OPERATIONS DIVISION****IC Sales Dept.****IC International Sales Group**

421-8, Hino, Hino-shi, Tokyo 191-8501, JAPAN  
Phone: +81-42-587-5814      FAX: +81-42-587-5117