

IMU (Inertial Measurement Unit) CAN INTERFACE

■ GENERAL DESCRIPTION

The M-G552PJ7 is a small form factor inertial measurement unit (IMU) with 6 degrees of freedom: tri-axial angular rates and linear accelerations, and provides high-stability and high-precision measurement capabilities with the use of high-precision compensation technology.

A variety of calibration parameters are stored in memory of the IMU, and are automatically reflected in the measurement data being sent to the application after the power of the IMU is turned on.

With Controller Area Network (CAN) interface support for host communication, the M-G552PJ7 reduces technical barriers for users to introduce inertial measurement and minimizes design resources to implement inertial movement analysis and control applications.

This unit is packaged in a water-proof and dust-proof metallic case. It is suitable for use in industrial and heavy-duty applications.

The features of the IMU such as high stability, high precision, and small size make it easy to create and differentiate applications in various fields of industrial systems.

■ FEATURES

Item	Specification
Sensor	
Integrated sensor	SEIKO EPSON inertial measurement sensor Low-noise, High-stability Gyro bias instability: 0.8 °/h Angular random walk: 0.06 °/√h Initial bias error: 360 °/h (1σ) / 3 mG(1σ) 6 Degree of freedom Triple Gyroscope: ±450 °/s Tri-axis Accelerometer: ±10 G 16bit data resolution Calibrated stability (Bias, Scale Factor, Axial Alignment)
Output data rate	100 sps (Default) Up to 1000 sps
LPF	Built-in moving average filter and FIR Kaiser filter
Interface	
Protocol	J1939 compatible
Physical Layer	ISO11898-2 (High speed CAN)
Frame format	CAN2.0B 29 bit-ID
Bit rate	250k bps or 500k bps
Node-ID	128 (programmable)
Other function	
Indicator	Green-LED / Red-LED
General specification	
Voltage supply	9 V to 32 V
Power consumption	32 mA (Vin=12V, default setting)
Operating temperature range	-30 °C to +80 °C
External dimension	
Outer packaging	Overall metallic shield case
Size	65 x 60 x 30 mm ³ (Not including projection.)
Weight	115 g
Interface connector	CAN connector: 5-pos, M12, waterproof
Water-proof, Dust-proof:	IP67 equivalent
Regulation (Applicable only for Mass production)	
EU	CE marking (EN61326/RoHS Directive) Class A
USA	FCC part15B Class A

■ APPLICATIONS

- Motion and vibration measurement
- Platform stabilization
- Attitude detection for unmanned systems
- Vibration control and stabilization

Appendix1. CONNECTOR SPECIFICATIONS

Connector specification

Model number	SACC-DSI-MS-5CON-M12-SCO SH(X)
Manufacturer	PHOENIX CONTACT

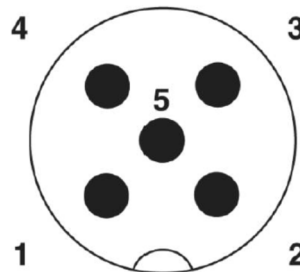

Terminal Layout

Terminal Function

No	Pin Name	I/O	Description
1	CAN_SHLD	-	CAN shield (*1)
2	CAN_V+	I	External power supply (9-32V)
3	CAN_GND	-	Ground
4	CAN_H	I/O	CAN H bus line
5	CAN_L	I/O	CAN L bus line

Notice: This unit should be connected to a connector that satisfies at least the IP67 water and dust proof specification.

(*1) CAN_SHLD is connected to the case.

Appendix2. J1939 MESSAGE OVERVIEW

Communication Settings

Item	Value	Note
CAN bit rate	250k bps / 500k bps	
CAN 29bit ID	-	CAN 11bits ID is ignored.
Address	128 (0x80)	Address is programmable.

Name Field

Field Name (J1939)	No. of bits	Byte No.	Value	Description
Arbitrary address capable	1	8	1	"Arbitrary address capable"
Industry group	3	8	0	"Global"
Vehicle system instance	4	8	0	
Vehicle system	7	7	0	"Non-specific system"
Reserved	1	7	0	
Function	8	6	145(dec)	"Inertial sensor"
Function instance	5	5	0	
ECU instance	3	5	1	
Manufacturer code	11	4,3	650(dec)	"Seiko Epson Corp."
Identity number	21	3,2,1	xxx	Unique number

Predefined Messages

Message Name	Direction	Priority	PGN	Description
Address claimed	in/out	6	60928 (0x00EE00)	Claim an address to use.

Proprietary Messages

Message Name	Direction	Priority	PGN	Description
Command	input	6	61184 (0x00EF00)	Command to the device.
Response	output	6	65504 (0x00FFE0)	Response for a command from the device.
SOUT1	output	6	65505 (0x00FFE1)	Angular rate data output
SOUT2	output	6	65506 (0x00FFE2)	Acceleration data output
SOUT4	output	6	65508 (0x00FFE4)	Temperature data output
SOUT5	output	6	65509 (0x00FFE5)	Time data output

OUTLINE DIMENSION

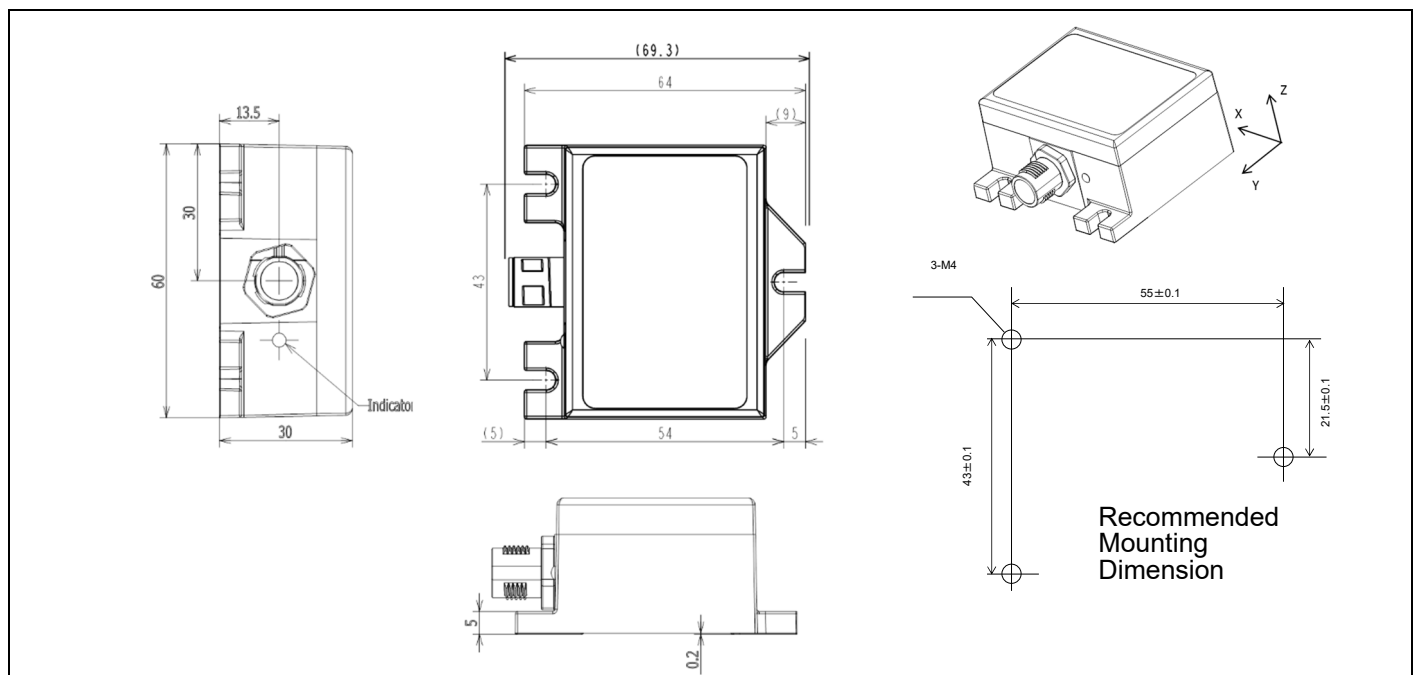

Outline Dimensions (millimeters)

Notice of the Document

NOTICE : PLEASE READ CAREFULLY BELOW BEFORE THE USE OF THIS DOCUMENT

The content of this document is subject to change without notice.

1. This document may not be copied, reproduced, or used for any other purposes, in whole or in part, without the consent of Seiko Epson Corporation ("Epson").
2. Before purchasing or using Epson products, please contact with our sales representative for the latest information and be always sure to check the latest information published on Epson's official web sites and sources.
3. Information provided in this document such as application circuits, programs, usage, etc., are for reference purpose only. Please use the application circuits, programs, usage, etc. in the design of your equipment or systems at your own responsibility. Epson makes no guarantees against any infringements or damages to any third parties' intellectual property rights or any other rights resulting from the information. This document does not grant you any licenses, intellectual property rights or any other rights with respect to Epson products owned by Epson or any third parties.
4. Epson is committed to constantly improving quality and reliability, but semiconductor products in general are subject to malfunction and failure. In using Epson products, you shall be responsible for safe design in your products; your hardware, software and systems are designed enough to prevent any harm or damages to life, health or property even if any malfunction or failure might be caused by Epson products. In designing of your products with using Epson products, please be sure to check and comply with the latest information regarding Epson products (this document, specifications, data sheets, manuals, Epson's web site, etc.). When using the information included in the above materials such as product data, chart, technical contents, programs, algorithms and application circuit examples, you shall evaluate your products both in stand-alone basis and within your overall systems. You shall be solely responsible for deciding whether or not to adopt and use Epson products.
5. Epson has prepared this document and programs provided in this document carefully to be accurate and dependable, but Epson does not guarantee that the information and the programs are always accurate and complete. Epson assumes no responsibility for any damages which you incurred by due to misinformation in this document and the programs.
6. No dismantling, analysis, reverse engineering, modification, alteration, adaptation, reproduction, etc., of Epson products is allowed.
7. Epson products have been designed, developed and manufactured to be used in general electronic applications (office equipment, communications equipment, measuring instruments, home electronics, etc.) and applications individually listed in this document ("General Purpose"). Epson products are NOT intended for any use beyond the General Purpose that requires particular/higher quality or reliability in order to refrain from causing any malfunction or failure leading to harm to life, health or serious property damage or severe impact on society, including, but not limited to listed below. Therefore, you are advised to use Epson products only for the General Purpose. Should you desire to buy and use Epson products for the particular purpose other than the General Purpose, Epson makes no warranty and disclaims with respect to Epson products, whether express or implied, including without limitation any implied warranty of merchantability or fitness for any particular purpose.
 - 【Particular purpose】
 - Space equipment (artificial satellites, rockets, etc.)
 - Transportation vehicles and their control equipment (automobiles, aircraft, trains, ships, etc.)
 - Medical equipment (other than applications individually listed in this document) / Relay equipment to be placed on sea floor
 - Power station control equipment / Disaster or crime prevention equipment / Traffic control equipment / Financial equipment
 - Other applications requiring similar levels of reliability as the above
8. Epson products listed in this document and our associated technologies shall not be used in any equipment or systems that laws and regulations in Japan or any other countries prohibit to manufacture, use or sell. Furthermore, Epson products and our associated technologies shall not be used for developing military weapons of mass destruction, military purpose use, or any other military applications. If exporting Epson products or our associated technologies, you shall comply with the Foreign Exchange and Foreign Trade Control Act in Japan, Export Administration Regulations in the U.S.A (EAR) and other export-related laws and regulations in Japan and any other countries and follow the required procedures as provided by the relevant laws and regulations.
9. Epson assumes no responsibility for any damages (whether direct or indirect) caused by or in relation with your non-compliance with the terms and conditions in this document.
10. Epson assumes no responsibility for any damages (whether direct or indirect) incurred by any third party that you assign, transfer, loan, etc., Epson products.
11. For more details or other concerns about this document, please contact our sales representative.
12. Company names and product names listed in this document are trademarks or registered trademarks of their respective companies.

2022.08

© Seiko Epson Corporation 2023. All rights reserved.

SEIKO EPSON CORPORATION

https://global.epson.com/products_and_drivers/sensing_system/contact/

Revised date JUL, 2023 in Japan
Rev.1.4

SEIKO EPSON CORPORATION